

HALCRO dm68 Super-Fidelity power amplifier

As I mentioned in the last issue, we had commissioned the University of Adelaide in Australia to establish an independent test for the distortion of dm68 through HALCRO's R & D director Bruce Candy. Beyond our expectation, Mr. "Candy" and Dr. Donald G McCoy Senior Lecturer in Physics in charge of this test are very efficient people. They finished all the measurements on 8th May, and e-mailed the result to us immediately. After we read these 4-page test report, we soon fell in utmost admiration of this Mr. "Candy" and believed that Dr. McCoy would have the same feeling, because the actual distortion of dm68 is not only much lower than the manufacturer claims, but also obviously far below the second and third order harmonic distortion of the best audio oscillator available in the market. What's more, even the most sophisticated spectrum analyzer can only measure distortion down to a few thousandths of a percent, which means 10,000 parts per billion, therefore, in order to carry out the test, people of the university shall design a unique circuit to solve these problems and then make those equipments work together. Process of measuring the distortion, content of this report, and the various special design features of this HALCRO amplifier will be introduced in the following pages.



The small audio giant



Since my fellow reviewers acknowledged my audition of the worldwide current lowest distortion amplifier—HALCRO dm68 at its distributor's, the only thing that they concerned most was about when the dm68 can be tested in our own listening room? Finally, at the end of April, we got the chance to review this great product in our own place. To get the most out of it, the associate equipments we choose were of top quality, including: Meridian 800 Reference DVD/CD player with 24-bit/192kHz upsampling and decoding module, Sony SCD-1 Super Audio CD player; Mark Levinson No.32 preamp; Revel's flagship loudspeaker Ultima Salon; Siltech SPO-180MF AC power cords; Kimber KS-103D and Straight Wire Crescendo interconnects; Kimber Bi-Focal XL speaker cables.

Not until I received the dm68, did I realize that this silver twin-towered amplifier is really HUGE. Although its footprint covers only 400mm x 400mm, the height of its vertical body reaches 790mm—the same level as a small floor-standing loudspeaker, and its weight 57kg per unit. So they just look like two small giants standing in our listening room.

Unclassified sonic character

Since we have been using Meridian Reference 800 DVD/CD player and Revel Ultima Salon for quite a long time (together with Mark Levinson No.32 preamp and No.436 power amp), we know exactly how the whole system sounds. So after we replaced the No.436 with dm68, sonic changes that would take place during the playback will clearly indicate the dm68's compatibility with other components, and its own potentials as well. And the result is...

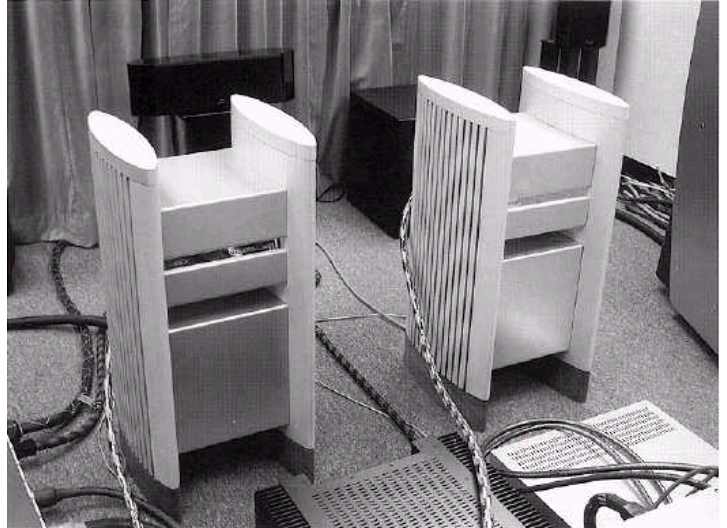

Frankly speaking, I'm not that qualified to say, "I've been familiar with all the best sounding components in the world", however, thanks to my profession and

as my profession requires, I have heard and reviewed a large number of high-end audio components. It's undeniable that you will hear differences from different components, but whatever startling or surprising you'll experience, they more or less can be classified into two traditional feelings--tube sound or solid-state sound. In contrast, the auditioning of dm68 proved to be a complete new experience. As it has solid and sweet sound performance along with a great level of musical involvement, you will not regard it as a solid-state amplifier; on the other hand, its stunning dynamic contrasts, incredible transient response, and the distinct outline of each stereo image will definitely not make you consider it a tube amp. While the output of dm68 is only rated at 225 W into 8Ω loads and 400 W into 4Ω, it still keeps an effortless control of the 6Ω load Salon while delivering abundant and precise bass power. The most impressive aspects of dm68 are probably related to the stated



super-low THD (Total Harmonic Distortion) and IMD (Intermodulation Distortion). Because it offers an ultra-quiet, almost "Pitch Black" super-low noise background, you will find much more never-before-heard details from your favorite CD collections than any of your previous similar experience. Additionally, as the subtle information contained in those recordings was drastically reproduced, details of harmonics of each instrument became exceptionally abundant, the different levels and three-dimensional sensation of the soundstage were also unprecedented. What attracts me most is its appealingly musical presentation that allows you a long-time listening. You can always hear something unexpected every time when you play a familiar soundtrack with dm68, and that will keep you selecting CDs for non-stop playback involuntarily. I believe nothing is more attractive than this inside a high-end component!

Personally, I think dm68 is truly one of a kind--its extraordinary sound performance combining all the advantages of both solid-state and tube amps. Now, you might oppugn: "What? Are you mad? Is it really

that good?” Yes. If I were you, and heard someone praise the equipment using such words, I’ ll question it too. But I can tell you that I exaggerated nothing. It really has a superb sonic performance so different from the others. And this is not a one-sided view: colleagues in our editorial office, reviewers and some visitors who came for dm68 also had the same view.

Comfortable and relaxing

For over a half of a month, the testing of dm68 has been an unforgettable pleasant time. Because it was not only the best sound that we have had in our listening room, but also changed my reviewing job into a happy enjoyment, whacko! So, how excellent does dm68 sound? Taking the playing of my favorite recording “Songs of A Tao”—a system-friendly and well-recorded folksong collection, it delivers more realistic sound than usual amps, and more sense of fresh air of being in the countryside, thus makes you feel getting much closer to the singer.

While listening to the humorous Track 7, you can feel that special wit and fun from A Tao’ s monologue accompanied by two guitars. His voice is loud, calm and thick, as if he’ s run the whole gamut of human experience. The vocal is so real that you may feel he’ s talking and laughing simply in front of you. Each note of every guitar is effortlessly and unmistakably reproduced with great clarity and smoothness. And music from the guitars is seamlessly blended with the monologue, offering you a comfortable experience and soon causing you into the artistic conception, and temporally forget what the Hi-Fi effect is. But, the tremendous sound effects such as the life-like 3D imaging, pin-point focus and precise object location remind you continuously that they all benefit from the existence of dm68.

Completely clear

Of course, dm 68 is definitely skillful in reproducing some music that can be rendered by a few instruments, for example, “The Four Seasons” violin concerto performed by Lu Si-qing and Toronto Camerata. But only when it replays the complicated large-scale orchestra with unbelievable dynamics, can you recognize its unparalleled “Super-Fidelity”. Reference Recording release of Pictures at an Exhibition (Eiji Oue / Minnesota Orchestra) had always been my essential disc for high-end audio test, especially the last two cuts: Baba Yaga and Great Gate at Kiev, which integrates all the Hi-Fi attributes: dynamic intensity, transient response, definition, tonal balance, extending of the high/low ends, width and depth of soundstage, transparency, and the 3D imaging. The performing of those two chapters deserves to be described as a reference presentation, and it’ s the best sound that we have had in our listening room for the last three years. Sector arrangement and depth of the orchestra was “displayed” in a smaller proportion (compared to its real size), but still “seems” bigger than our room. In Great Gate at Kiev track, you can easily point out here’ s a clarinet and there’ s a bassoon. Even though their pitches and locations are quite close, you can still tell the differences. At the grand dynamical final, the tiny triangle was not submerged by the whole, and even the die-away process of residual vibration of gong can be heard quite naturally and clearly.



Listening is believing

Searching my heart, I found no flaw in dm68' s superlative performance by any standard, but to nitpick, the cost of HK\$300.000 and the massive dimension of 790×400×400 mm could be things to complaint about. HALCRO is just a new brand from Australia, that' s all? Who cares!

If I continue describing the listening process, I would write nothing but more praises, therefore I think the best way to understand the dm68 is to read the following detailed report by Raymond, and then go and hear it yourself.

The Ultimate Stature

Design features and sonic performance of HALCRO dm68 Super-Fidelity power amplifier

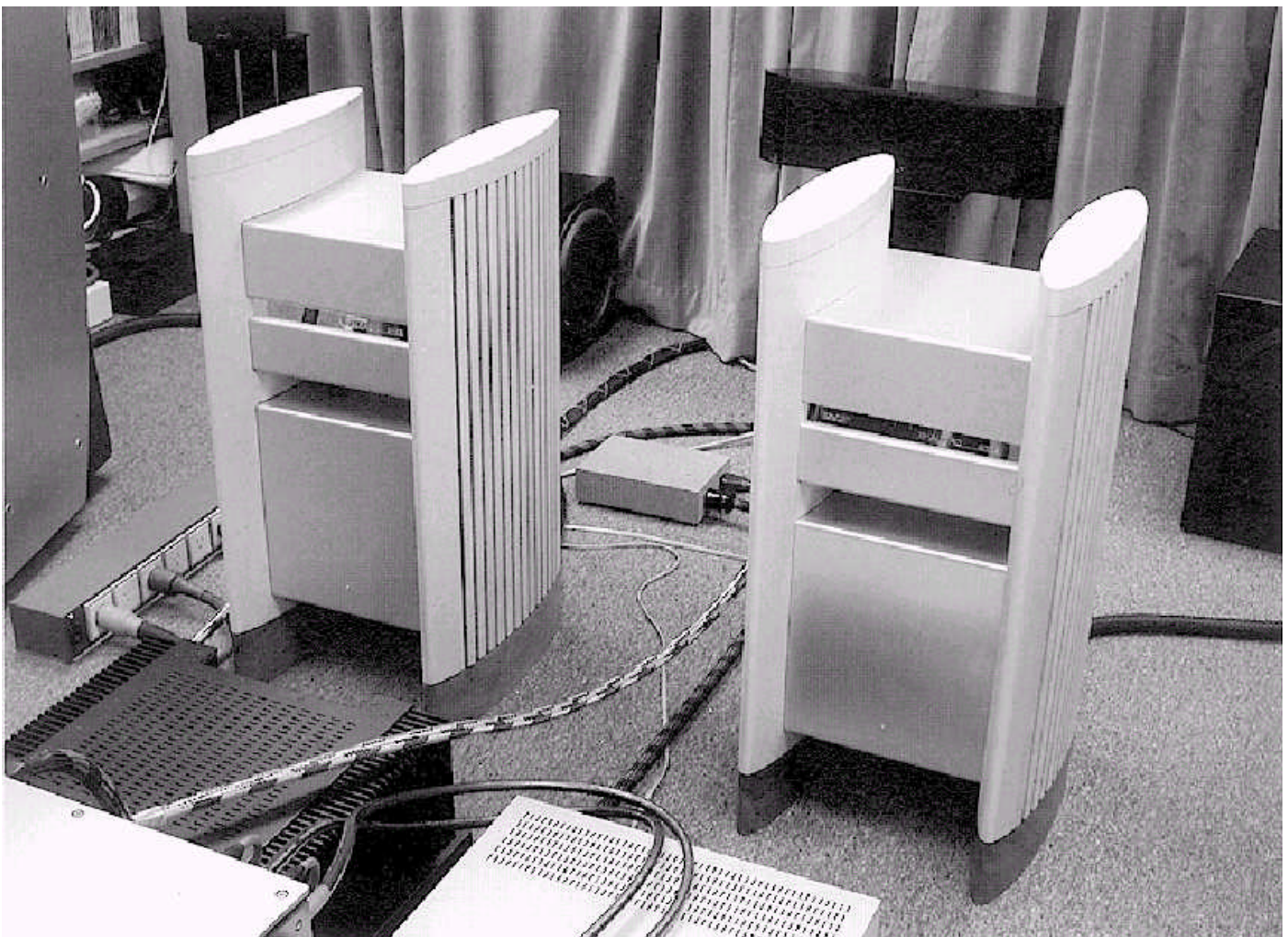

A majority of people felt that it was meaningless to run after the specifications in regard to the present high-end audio equipments, as a large number of solid-state amplifiers are able to achieve an exceptional level of distortion under the typical test conditions. However, the fact is that very few of them can sound best. On the contrary, tube amps are famous for their sweet and soft sound performance, but the distortion they exhibit could be ten times greater than the solid-states' . Such kind of situation has been widely accepted for many years, and here are the deductions: sound performance has no "direct" relationship with the distortion; and no matter how much effort the designers make, different amplifiers will always have their own unique sonic characters.

The above specious “theory” has never been challenged. Amateurs accepted it; critical audiophiles accepted it; and even some experts accepted it! Those “theory” became a common sight and nobody could try to deny it, and in addition, people would take use of it as their means of fine-tunes. Using components from different models of different manufacturers result in many kinds of sound. Therefore, unique character becomes a matter of course and inevitable.

Anyway, audio equipments are hi-tech products. It’s an improper and reasonless behavior if we only care about the matching of different components and put the specifications aside. But once the rule is broken, there will be a whole new world, and the moment has already come.

HALCRO dm68 is the very rule-breaker. As compared with other audio components or even many professional instruments, its high standard specifications and super-low distortion are appalling. The output power of dm68 is 225W (8 Ω), 400W (4 Ω); and it produces only 1,000 parts per billion (0.0001%) harmonic distortion at 20kHz at full power! In comparison, some other high quality amplifiers produce the distortion of 200,000 parts per billion, which is 200 times larger than that of dm68. Such a high standard specification cannot be obtained by only one or two technical breakthroughs but by comprehensive improvements of multiple techniques. HALCRO has paid close attention to every detail and their innovative designs, and on this point, they are now unparalleled.

dm68 shares almost the same overall circuit topology as the conventional amplifiers, containing input stage, voltage amplifying stage, output stage. And what makes HALCRO so different is that all the modules employed are meticulously designed to reduce distortion. Additionally, the input and output parameters of each stage are also carefully trimmed for optimizing signal transmission, for example, the impedance, gain and phase transfer etc.

Fully shielded

dm68 does not use overall feedback to lower the distortion as that is the parent of transient intermodulation distortion. Since dm68 has very low distortion in all stages, it’s unnecessary to make correction by applying feedback owing to the minimal accumulative errors.

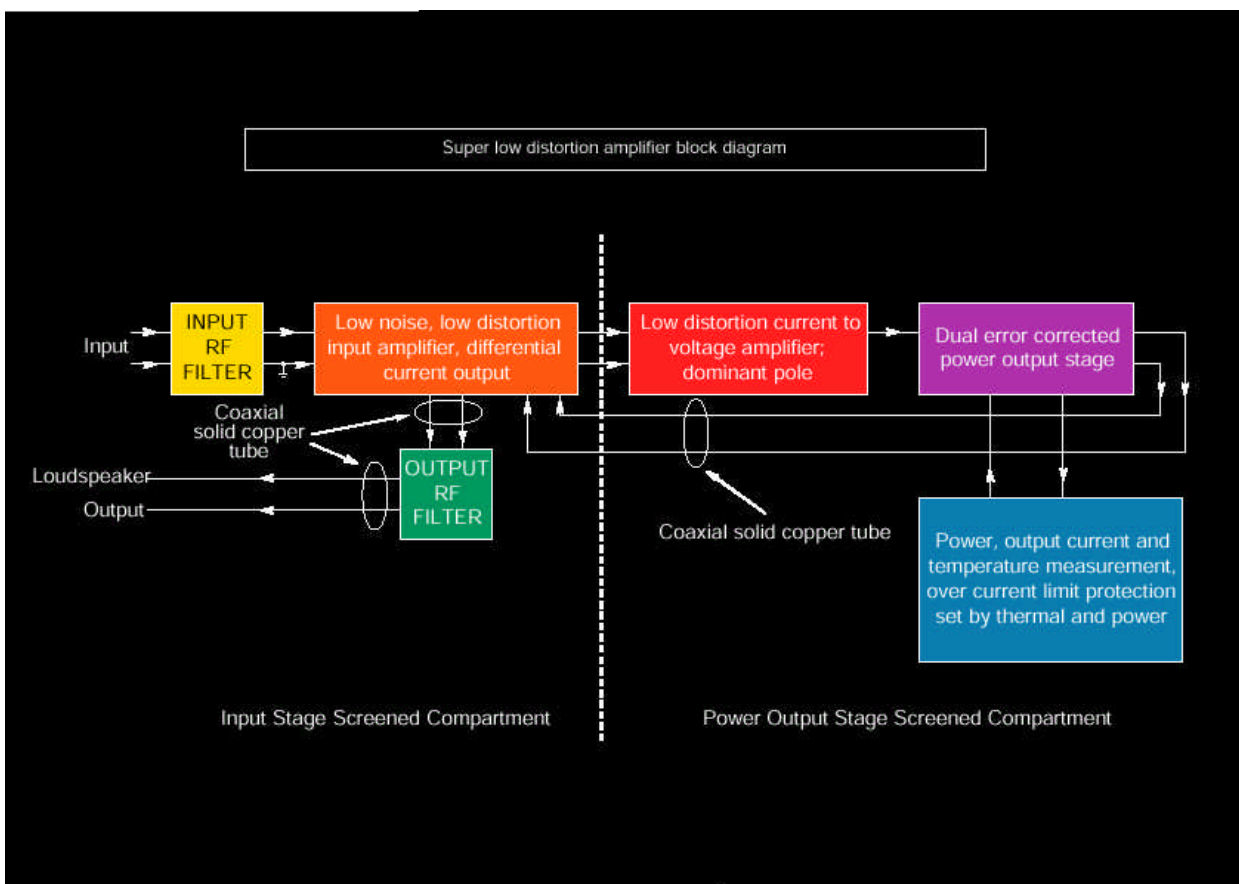

Super low distortion amplifier block diagram clearly shows the special configuration of dm68: it has four shield boxes, which are used for power supply, input, voltage amplifying and output filter circuit respectively. Now, let's put the circuit design aside for a while and talk about the internal connection first. Quite unlike the others, between output stage and speaker terminals, dm68 utilizes a substantial gold-plated coaxial solid copper tube. From the photo, you can see that it's as thick as a baby's arm; and more special thing is at the signal input stage and power output stage—they're all equipped with a RF filter. The aim is simple: to isolate the dm68 from the external interference and eliminate the interactions between the internal devices and circuits.

No compromise in component quality

While we call it super amplifier, the components it uses must be extraordinary, but dm68 has even gone further—it employs industrial grade components that are able to operate over a range of -40 degrees C to +85 degrees C. They are obviously superior to the usual commercial grade components, which are only rated between 0 to 70 degrees C. And because the operational life of electrolytic capacitors is subject to temperatures, dm68 uses the higher standard 105 degrees C capacitors rather than the usual 85-degree ones, the mean lifetime of the higher temperature rated capacitor is 180,000 hours and the later one is only 50,000 hours at 40 degrees C.

To reduce the stray fields and achieve a stable and precise line voltage, dm68 utilizes a six-layer circuit board for its voltage amplifying stage. Even though multi-layer PCBs are rarely used in the power supply section, dm68 still equipped a four-layer circuit board to minimize the electromagnetic interference (E.M.I.) and transient voltage without considering the cost.

Unprecedented protections

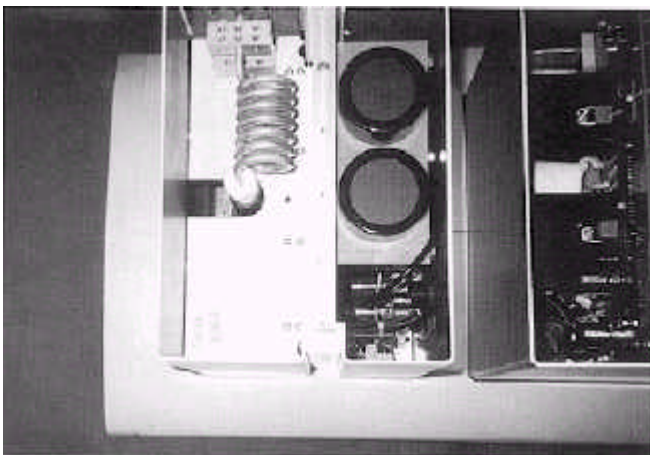

Fig 1:
Coaxial solid output copper tube through the shield box of input stage. The exquisite spiral construction should be the output filter section, which takes the advantage of inductive effect.

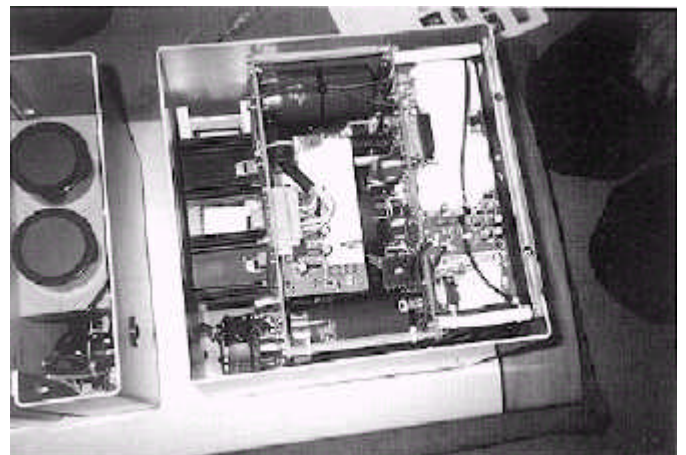

Fig 2:
The bottom compartment of the twin-towered construction is the first door to the switch mode power supply. Materials that painted in white on the circuit board are used for cooling. There's a black round object located under the bottom of top compartment, and that is the never-before-seen air pressure switch.

It's not new for amplifiers to have their protection system, but so many protections employed in dm68 are really unprecedented, especially the maximum output current limiting within the power output circuit. HALCRO believes the present fashionable design concept that amplifier must have very high current output is impractical and spurious. Because the impedance of a well-designed loudspeaker will not vary much from its nominal impedance,

for example: drastically down to 1Ω from 4Ω . Also, the output current of tube amp is limited by its output transformer, and thus unable to deliver high transient current, but it still sounds good and hardly overloads. In fact, if the loudspeaker impedance suddenly decreased from 4 or 8 ohm to 1 ohm, whatever the load is impedance or reactive or capacitive, the amplifier is almost shorted out. Even if the amplifier is able to deliver high current to compensate, I still want to ask: in what way the heat generated will be radiated assuming the 1-ohm load is resistive? And how to explain such a poor transduction coupling if it's reactive? Then, I think that making amplifiers to deliver excessively high output current to drive the loudspeakers that have an impedance of 1 or 2 ohm is virtually creating a fault condition deliberately. We shall avoid this situation rather than let it be.

dm68 has seven major protection systems. Firstly, the output power FETs protection: proprietary circuits are applied to inspect and calculate the average power consumption and heatsink temperature, then adjust the output current.

If there's any DC offset occurs in the output, no matter it's positive or negative, an independent circuit will shut the amplifier off for protection. This circuit also has another function: when any unusual current lasts for an unreasonable length of time is detected, it will shut down the amplifier too.

At the power supply section, protection system will automatically limit the maximum available output current. It has no influence on the regular sound performance and will reduce the maximum current as soon as possible when the fault shows up. Furthermore, dm68 owns two independent over temperature cut outs and another two independent master clock fault sensing circuits. All the power supplies have under-and over-voltage and over current protection; the small signal power supplies are even equipped with transient diode over-voltage protection.

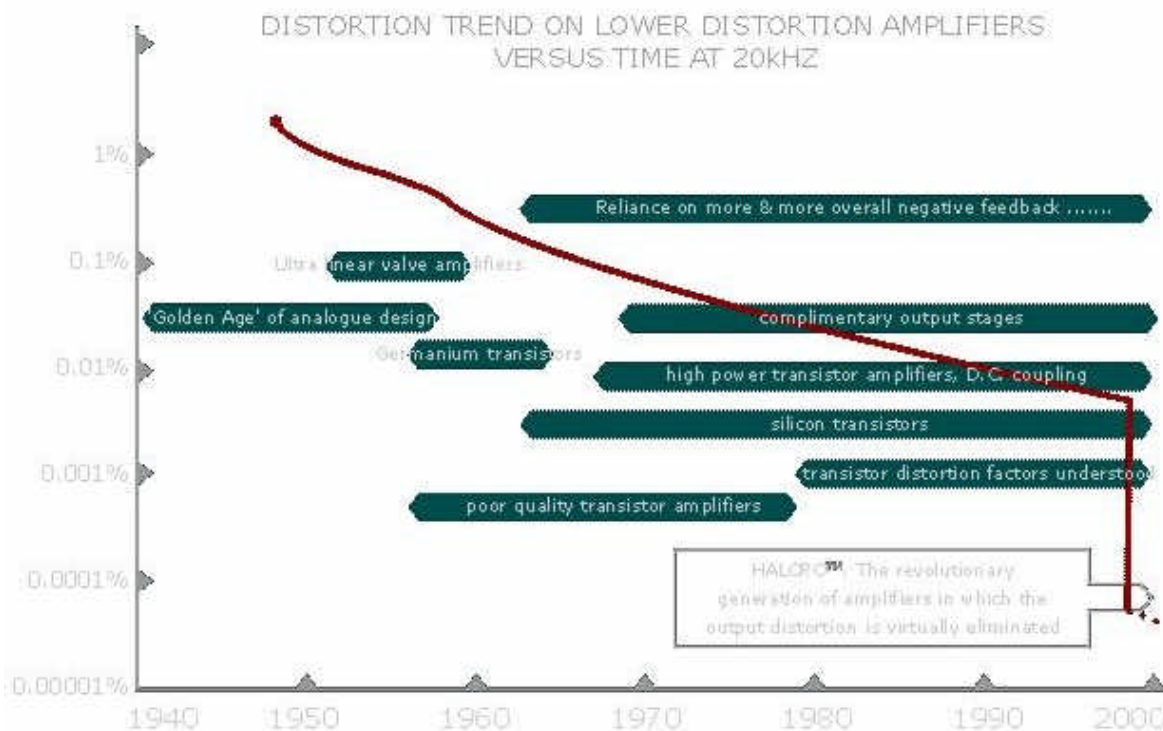

dm68 has already incorporated a lot of bedazzling protections, but in the mains input, it still employs transient over-voltage protection that can only be seen in the filtering circuit. The protection system consists of three independent circuits: two of them are responsible for the surge voltage absorbing and the rest is used for inductive filtering. I've been an electrician for many years, and seldom find any other amplifier having such "abundant" protections as dm68—It's awesome! As an electrical "equipment" that adopted so many protections, the dm68, I believe, will be home free even it facing the electromagnetic pulse caused by a nuclear explosion.

Meticulous circuit design

Power supply circuit

The power supply of dm 68 features switch mode design. This kind of design has clear advantages and disadvantages: it's highly efficient, generates less heat, and operates over a very wide current and voltage range etc; but such a high-speed action will also produce noise and interference just as conventional switch power supply does. The switching frequency of dm68 is above 100kHz, in another word, far beyond the audible range. Besides, the ultra-high switching frequency is fixed, thereby it has no adverse effect on the AC mains and will make no surge current either; the ripple factor of DC output current is remarkably low: about 100 ppm. This high-speed switch mode power supply also has another two unique functions: first, adapting itself to a wide range of input mains voltage automatically—from 85V to 270VAC, so that dm68 can be used all over the world; second, adjusting the power factor automatically. In fact, this technique was originally used for improving efficiency of the electrical appliance. As the power factor gets much closer to "1", the electrical appliance will act more like a pure resistor. Unlike the capacitor and inductor, resistor doesn't have a process of charging or discharging, so, it's an ideal load. The switch mode power supply of dm68 becomes a tool of combining the amplifier circuits and AC mains ideally, not only a power provider for the electronics.

Audio circuit

There's no significant difference between the dm68 audio circuit and conventional designs as they all consist of three parts: input stage, voltage amplifying stage and power output stage. The task of input stage is to buffer the input signals of different standard, and convert them into the same ones which are optimized for voltage amplifying stage. dm68 utilizes low noise, ultra low distortion differential voltage amplifier plus differential current output, and current mirror.



The voltage amplifying stage comprises a low distortion current-to-voltage converter, includes the dominant pole. All those circuits employ typical design and common techniques—there are nothing special but this: HALCRO don't follow the current fashionable "fully symmetrical" design, because they believe that the symmetric circuit theoretically and practically cancels only even harmonic distortion, while human ears dislike odd harmonic distortion, HALCRO suggested that all the designers not adopt the symmetric design if they want to get rid of odd harmonic distortion. Therefore, no second order dominant pole was used in the dm68's voltage amplifying circuit, and this results in excellent frequency response and super-low distortion.

The existence of second order dominant pole does have somewhat help for distortion reduction, but it will load the voltage amplifier heavily and then decrease the slew rate. dm68 successfully eliminates the implementation of such poles and makes the slew rate up to $100\text{V}/\mu\text{S}$ (rising 100V in 0.000001s). As you may know, the same parameter of LT1028 IC amp—a favorable device for many DIY audiophiles is just $50\text{V}/\mu\text{S}$; and the rate of NE5534—used by numerous current audio equipments is much lower: $13\text{V}/\mu\text{S}$. Even in the slowest power amplifying stage, dm68 still demonstrates a slew rate of $65\text{V}/\mu\text{S}$. What a SPEED!

dm 68 uses FETs in its power output stage, and the quiescent current is intentionally adjusted to a higher level to minimize the crossover distortion. HALCRO also find that many so-called class AB amp designs will produce considerable crossover distortion while current in the push-pull power amplifier move from the forward amplification to the reverse amplification, even the power FETs are not completely turns off. But the HALCRO amps are designed to deliver more natural and moving sound while working in the heater-like Class A operation without excessive heat.

The bandwidth of output stage is not too wide and just a little bit higher than the average level. Since the distortion of its own circuit is super-low, it is unnecessary for dm68 to reduce the distortion by using overall feedback, thus bring to it another two advantages: 1) eliminate transient intermodulation distortion; 2) minimize the non-linear effects such as variable capacitance of the semiconductor.

To prove HALCRO's claim is justified and valid, the Adelaide University of Australia have accepted our commission for testing dm68. According to the test report we can see that the fourth order harmonic distortion was just 210 parts per billion when driving a 4 ohms load at the upper end 20kHz. Ironically, all the test equipments have greater distortion than the amplifier itself, so the test group designed a special circuit to carry out the measurements with a precision signal amplifier LT1226 and some other instruments (see Fig below): through adjusting E (variable capacitor) and F (variable resistor), distortion from the audio signal generator can be automatically canceled, otherwise, performing such an experiment would be a *mission impossible*.

In addition to the measurement of harmonic distortion, IMD and amplitude modulation tests were also be made. A signal mixed with 19kHz and 20kHz was used for IMD test under the condition of approximate full power output. Of course, to most amplifiers, that's a game of death, but dm68 passed it easily; the result of 1kHz amplitude modulation was only 99 parts per billion, and found no 1.8kHz, 2kHz and 17kHz modulation distortion. Amplitude modulation measurement was made with a 32V, 60kHz signal and an 8V, 7kHz signal, since the distortion was unmeasurable, there's no test result.

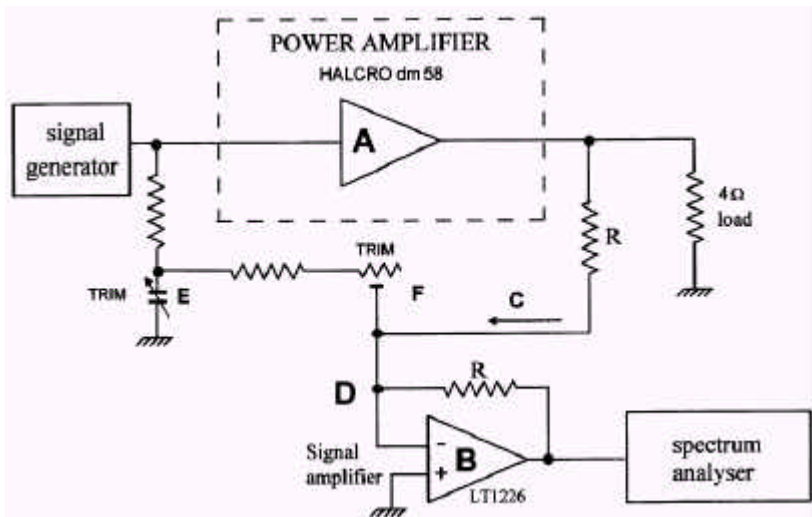

There's one more thing that hasn't been referred in the dm 68 technical literature, and I think it's truly an outstanding design—air pressure power switch button, which allows best possible positioning and minimal interference.

It's truly a "real" sound

It's not easy to clearly express the feeling of hearing dm68. As I failed in searching my brain for proper words to describe it, I have to say that I've never heard an audio component which can sound like this. It has sweet voice of tube amp, almost limitless frequency response which is full of nuance and delicacy, hi-resolution reproduction similar to the magnifying ability of a microscope, and no matter what type of music or instrument it plays, the extending of ultra highs and attenuation of harmonics of the percussion instruments are both dealt in completely natural ways. We once used Sony SCD-1 as the source end during our listening test, and found it reveals more details than ever, especially the richness of ambience playback—that's a difference between music concert and large stadium. It seems very difficult to draw a direct comparison with the other products regarding the dynamic range: dm68 enables you to feel the sound of the tiniest needle falling on the ground, and also capable of giving you a great punch without any limitation in speed and force.

I did feel soulless after my auditioning of dm68, and awared what the high-fidelity really is. I also became so frustrated when I knew its retail price and wondering if there will be any chance of owning one in this life.